

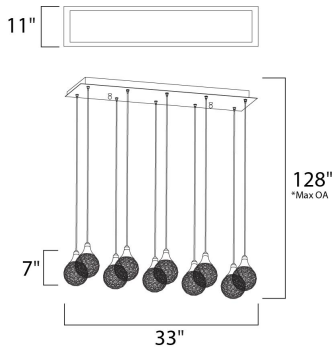

PRODUCT DESCRIPTION

With formed metal spheres of Polished Chrome framing multifaceted crystal jewelry, the Brilliant Collection adds a touch of contemporary elegance to any design space. The illumination of xenon lamps reflecting through the crystal offers added brilliance by creating a spectrum of color.



*max overall height

MEASUREMENTS

DIMENSION : 33" L x 11" W x 7" H
 MAX OAH : 128" OAH
 HANGING WEIGHT : 24.2 lb

LAMPING

LUMENS : 5,000 Rated
 BULB : 1 x 40W Xenon G9 , 400W Total
 BULB INCLUDED : (Included)
 DIMMABLE : Yes
 COLOR_TEMP : 2900K

FINISHES OPTION



GLASS

Crystal 20

MATERIAL

Steel, Crystal

RATINGS

cETLus
 Dry Location



ADDITIONAL

RATED LIFE 2000 Hours
 OPERATING TEMPERATURE:
 -20°C (-4°F), 40°C (104°F)

Always consult a qualified electrician before installing any lighting product.



WESTERN DISTRIBUTION CENTER (HEADQUARTER)
 253 NORTH VINELAND AVE | CITY OF INDUSTRY, CA 91746
EASTERN DISTRIBUTION CENTER
 4200 SHIRLEY DR. | ATLANTA, GA 30336
 P. 626.956.4200 | F. 626.956.4225 | et2online.com